

TLN WRO Specification type Document

< Specification and Certification for AO Modem >



telenet

Document Housekeeping

Document Category and type

CAT	TYPE	DOC ID	Comment
Broadband	SPEC	TLN-WRO-TA-B-S-PAAA	Specification type documents (-SPEC) are documents specifying logical/physical interfaces/protocols, etc., to which AO equipment/systems need to comply

Document Status

EDITION	DATE	STATUS
1.0	09.10.2013	Final
2.0	29.12.2018	Final

Legal Disclaimer

"This document constitutes an integral part of the Telenet Reference Offer for Basic TV / IDTV / BB and should be fully complied with by the Beneficiary at all times. Non compliance, incomplete or deviating application of this document by the Beneficiary, or his authorized agent, results in the suspension and ultimately termination of the Contract between Telenet and the Beneficiary.

At any time this document is susceptible to change by Telenet, Regulator's decision or by decision of a relevant judicial authority. Changes to this document will, depending on the circumstances for change, be appropriately notified to the Beneficiary and published on the Telenet website.

Telenet has appealed the CRC decisions of the VRM, BIPT and CSA of 29 June 2018 concerning the market analysis of the broadcasting and broadband market in Belgium and it consequently reserves all its rights in relation to this document."

Table of Contents

1	Abstract	6
2	AO Euro-Docsis 3.0 CPE General Functional Description	7
3	AO Euro-Docsis 3.0 CPE General Functional Requirements	8
3.1	AO EURO-DOCSIS 3.0 CPE HARDWARE AND OS	8
3.2	EURO-DOCSIS MAC AND IP LAYER	8
3.2.1	MAC layer	8
3.2.2	IP layer	8
3.2.3	Control plane.....	8
4	AO Euro-Docsis 3.0 CPE HFC and Euro-Docsis 3.0 Physical Layer Functional Description	10
5	AO Euro-Docsis 3.0 CPE HFC and Euro-Docsis 3.0 Physical Layer Functional Requirements	11
5.1	EURO-DOCSIS 3.0 PHYSICAL LAYER.....	11
5.1.1	Euro-Docsis 3.0 physical layer general requirements	11
5.1.2	Euro-Docsis 3.0 physical layer TLN specific requirements.....	11
5.2	OLDER DOCSIS VERSIONS.....	11
5.3	TLN DOCSIS SPECTRUM PLAN	11
5.3.1	Docsis downstream carriers frequency plan	11
5.3.2	Docsis downstream RF signal coding and signal levels	11
5.3.3	Docsis upstream carrier low and high band plan.....	11
5.3.4	Docsis upstream carriers frequency plan.....	12
5.3.5	Docsis upstream RF signal coding and signal levels.....	12
5.3.6	Docsis upstream hopping channel concept.....	12
5.4	TLN DOCSIS RANGING AND CARRIER SIGNALLING PROCEDURES.....	13
5.5	TLN DOCSIS CARRIER SPECTRUM PLAN	13
6	AO Euro-Docsis 3.0 CPE MAC and Upper Layer Functional Description.....	14
7	AO Euro-Docsis 3.0 CPE MAC and Upper Layer Functional Requirements.....	15
7.1	EURO-DOCSIS 3.0 MAC AND UPPER LAYER.....	15
7.1.1	Euro-Docsis 3.0 Mac and upper layer general requirements	15
7.1.2	Euro-Docsis 3.0 Mac and upper layer TLN specific requirements.....	15
7.2	EURO-DOCSIS 3.0 SECURITY.....	15
7.2.1	Euro-Docsis 3.0 Security layer general requirements	15
7.2.2	Euro-Docsis 3.0 Security layer TLN specific requirements.....	15
7.3	EURO-DOCSIS 3.0 OSSI	16
7.3.1	Euro-Docsis 3.0 OSSI general requirements	16
7.3.2	Euro-Docsis 3.0 OSSI TLN specific requirements	16
7.4	EURO-DOCSIS 3.0 BSOD: L2VPN.....	16
7.4.1	Euro-Docsis 3.0 BSOD: L2VPN general requirements	16
7.5	OLDER DOCSIS VERSIONS.....	16
7.6	AO CPE MAC AND IP LAYER PROVISIONING: "OFF-LINE" STAGE	16
7.6.1	AO Docsis CPE asset white list upload.....	16
7.6.2	AO Docsis CPE modem configuration template upload.....	17
7.7	AO CPE MAC AND IP LAYER PROVISIONING: "ON-LINE" STAGE	18
7.7.1	AO Modem activation flow	18
7.7.2	AO Docsis CPE "Management" IP address Assignment.....	18
7.7.3	AO Modem configuration	18
7.8	IP LAYER CONNECTIVITY FOR AO DOCSIS CPE	19
7.8.1	BSoD	19
7.8.2	Access Authentication.....	19
7.8.3	IP Address assignment.....	20
8	AO Device Management by TLN Requirements	21
8.1	CONCEPT AND PURPOSE	21
8.2	DEVICE MANAGEMENT FUNCTIONS.....	21
8.3	SNMP MIB SPECIFICATIONS.....	21
8.4	RESET AND FACTORY RESET SPECIFICATIONS	22
9	AO Euro-Docsis 3.0 CPE-Non Functional Requirements.....	23
9.1	MECHANICAL REQUIREMENTS.....	23
9.1.1	Housing.....	23
9.1.2	Diagnostic Leds.....	23
9.1.3	Labels.....	23

9.1.4	Connectors	23
9.2	ENVIRONMENTAL REQUIREMENTS	24
9.2.1	Packaging	24
9.2.2	RoHS and WEEE compliancy	24
9.2.3	EU CoC compliancy	24
9.3	SAFETY REQUIREMENTS	24
9.3.1	Surge and Lightening protection	24
9.3.2	Temperature and Humidity	24
9.3.3	Fire resistance	24
9.4	EU CONSUMER GOODS LABEL REQUIREMENTS	25
9.4.1	CE - mark.....	25
10	Certification procedures for AO Euro Docsis 3.0 CPE to enable usage of TLN ROBB	26
10.1	INTRODUCTION	26
11	Test score card	26

Table of Figures

Figure 2-1:	AO Euro-Docsis General Overview	7
Figure 3-1:	CM initialization	9
Figure 7-1:	AO Docsis CPE modem configuration	17
Figure 7-2 :	AO Modem Activation Flow	18
Figure 7-3 :	BSoD Tunneling	19
Figure 7-4 :	Access Authentication	20
Figure 9-1:	Safety Requirements Standards	25

List of Appendixes

This document may refer to further detailed documents that are added in Appendixes to this document.

A reference to an appendix is in this document highlighted with grey background.

The list of appendixes to this document:

Appendix 1: APP_TA_B_S_PAAA-A-Telenet.CNG.AINE-QCR-CM-EMTA- Lightning-REQ-20080730

The appendix(es) referred to in this section List of Appendixes, contain(s) detailed technical information which is only relevant when a Beneficiary enters in a concrete implementation project to become Beneficiary of the Telenet Reference Offer and/or Annex.

List of References

This document may refer to external documents or information sources.

A reference to an external document or information source is in this document highlighted with grey background.

The list of referred external documents or information sources in this document:

Reference 1: TLN_WRO_TA_G_S_PAAB_ Specification Device Management

Reference 2: TLN_WRO_TA_G_C_PAAA _ General Certification Procedures

Restricted information

This document may contain sections that are not public information and that can be made available only to parties that have executed specific NDA`s.

Information that is subject to NDA is marked in this document as follows:

NDA

The information in this text box is available only under NDA

NDA

Before conversion to PDF format for publication of the document, the information will be made unreadable by converting the background of the text box to black.

1 Abstract

This document describes the major building blocks an AO Euro-Docsis 3.0 CPE must contain in order to be able to successfully interoperate with the TLN BB WRO. Each required building block is briefly described explaining it's expected functional behavior.

Additionally, non-functional requirements for the AO Euro-Docsis 3.0 CPE are also described in this document.

Generic sections specifying certification procedures applicable to all AO CPE or network equipment that will be connected to the TLN network are described in General Certification Procedures Document TLN_WRO_TA_G_C_PAAA _ General Certification Procedures.

2 AO Euro-Docsis 3.0 CPE General Functional Description

- (1) The conceptual block diagram of an AO Euro-Docsis 3.0 CPE is shown in figure 1 below.
- (2) In summary, the AO Docsis CPE realizes the set-up of an IP data communication path between the customer premises LAN side of the AO Docsis CPE and the Internet. This operation proceeds by tuning on the Docsis carriers on the TLN network, authenticating the device and obtaining a valid IP address and other data communication parameters to set-up the data path.

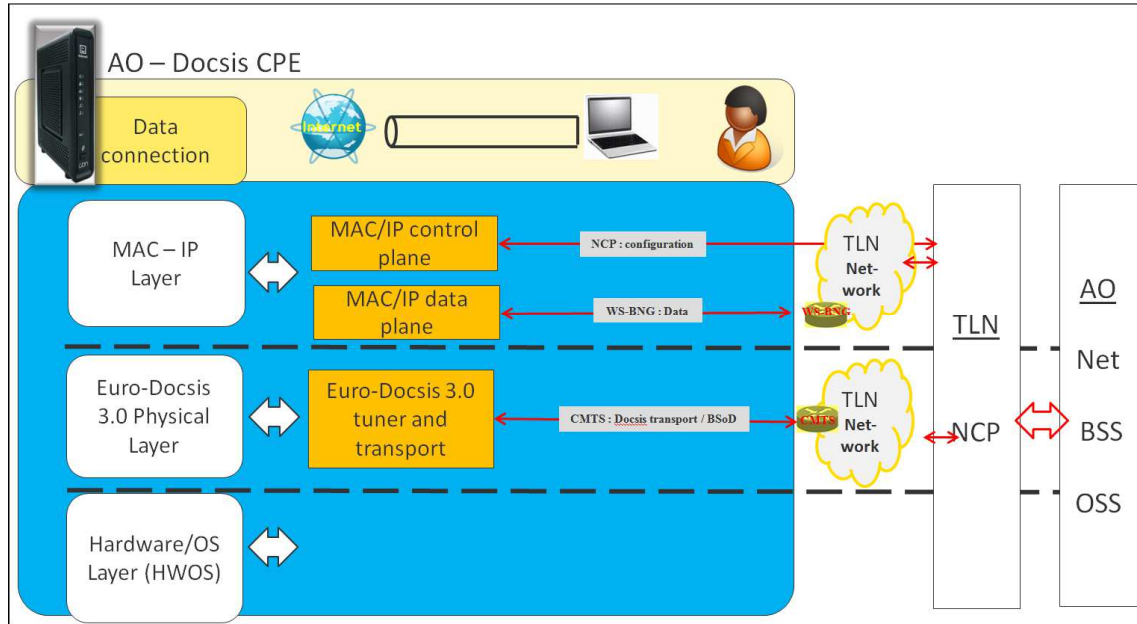

Figure 2-1: AO Euro-Docsis General Overview

3 AO Euro-Docsis 3.0 CPE General Functional Requirements

3.1 AO Euro-Docsis 3.0 CPE Hardware and OS

- (3) TLN does not impose specific requirements on AO Docsis CPE HW and OS. The AO is free to choose any type of HW or OS as long as the overall solution can support the complete set of requirements for the TLN BB WRO.

3.2 Euro-Docsis MAC and IP layer

- (4) This functional implements the data-plane MAC layer, IP layer as well as the related control plane protocols for initializing, setting-up and securing the MAC and IP data-plane layers.

3.2.1 MAC layer

- (5) The first step for an AO Docsis CPE to establish data communication with the TLN network is to build up the MAC layer with the CMTS. Before Data Connection can start, the CPE must communicate with the TLN CMTS to initialize the Docsis layer. After completing this operation, the AO Docsis CPE (Cable Modem) belongs to the CMTS MAC Domain. The MAC Address for allowable CPE is held in a TLN network database for verification and should also be held by the AO in its own databases.

3.2.2 IP layer

- (6) Two major functions are implemented on this layer; L3 IP address assignment and AAA (Authentication, Authorization, and Accounting). The AO Docsis CPE launches a DHCP request that sends the related information for Authentication with the AO-NCP passing via the TLN-NCP that will verify and proxy this information. After this process, IP address assignment is provided and the data path is established for AO Docsis CPE traffic that is transported through the TLN access network using Business Services over Docsis (BSoD) L2VPN technology to the WS-BNG.

3.2.3 Control plane

- (7) The TLN NCP is the main building block involved in establishing initial the session set-up and steps involved in bringing an AO CM in “on-line” status ready for data transmission. This includes initial CM configuration (dynamic process upon CM “cold” start), acquisition of a CM “management” IP address (the address of the modem itself), acquisition of IP addresses for end-user devices sitting “behind” the CM mode, on the LAN side (for CM’s that contain router functionality and are using NAT (so called Docsis Home Gateways), this is typically the home gateway WAN interface IP address. The TLN NCP (a collection of several servers and control plane modules in network elements), dialogues with its counterpart the AO NCP (implementation is AO choice) using standard interfaces. The TLN NCP will “relay” relevant end-user session establishment events (such as address acquisition requests) to the AO NCP, so that the AO NCP (which will be coupled to the AO CRM and/or AO OSS/BSS) can participate at maximum in this process with as goal to establish maximum flexibility in the AO service offering.
- (8) The beginning of the CM initialization process is triggered by the AO Docsis CPE (CM) launching a DHCP discovery; that contains among other parameters, at least vendor-type, modem type, DOCSIS capabilities and hfc-mac-id. The TLN-NCP checks the AO-ID by using hfc-mac-id. If it is not white-listed in the TLN AO DB, the modem will not be able to initialize on the AO network.

- (9) Next step is that the TLN-NCP will pick the correct modem configuration file for that AO modem (which has been uploaded to TLN modem file configuration servers upfront via an off-line FTP upload process), apply it to the modem and assign a “management” IP address from TLN’s private address space.
- (10) The CM config file contains parameters for setting up BSoD based transport to the CMTS. With the help of this info a virtualized data forwarding path to the WS-BNG is established. Below one can see this process explained in the figure.

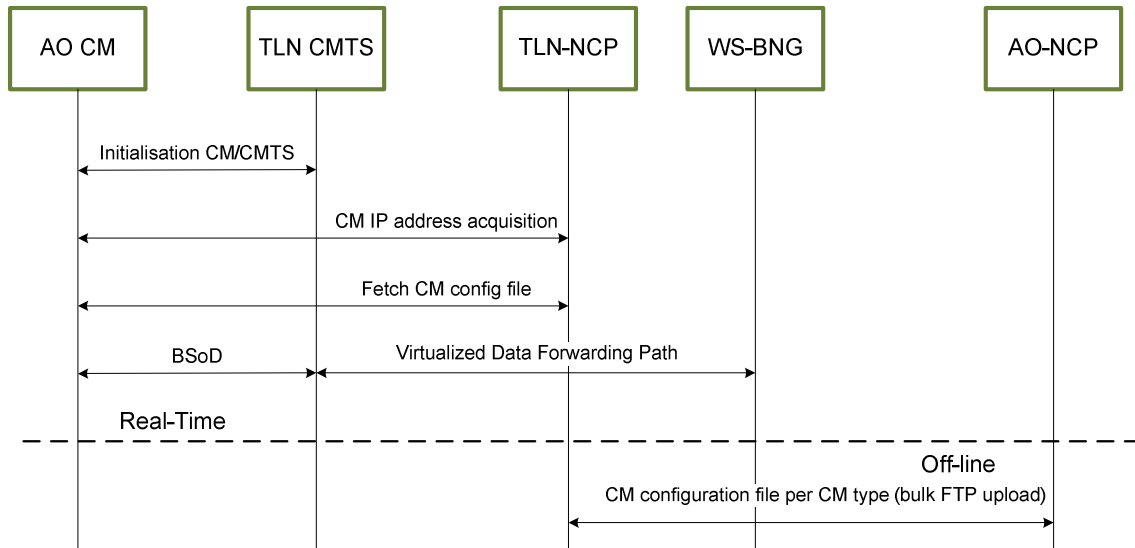

Figure 3-1: CM initialization

4 AO Euro-Docsis 3.0 CPE HFC and Euro-Docsis 3.0 Physical Layer Functional Description

- (11)The overall function of a Docsis CPE is to enable IP data communication between devices in a customer home and the Internet. Two major distinct interfaces and communication layers are present in a Docsis device. The first one addresses the HFC and Docsis physical layers, the second one addresses the MAC and IP layer interfaces. As TLN operates in a Euro-Docsis environment, all references to Docsis or Docsis specifications implicitly refer to the Euro-Docsis variant.
- (12)The next chapter addresses the HFC and Docsis physical layers. It describes the electrical requirements for signal transmission between an AO Docsis CPE and the TLN HFC network as well as the basic Docsis ranging, registration and scheduling procedures and protocols that are used to establish a MAC layer communication between the AO Docsis CPE and TLN CMTS

5 AO Euro-Docsis 3.0 CPE HFC and Euro-Docsis 3.0 Physical Layer Functional Requirements

5.1 Euro-Docsis 3.0 Physical Layer

5.1.1 Euro-Docsis 3.0 physical layer general requirements

- (13) In order to ensure successful interoperability on the physical layer the AO Euro-Docsis CPE device must conform to the Docsis 3.0 physical layer specifications (Euro-Docsis variant) as published in the public Docsis 3.0 specification library on www.cablelabs.com.
- (14) As a minimum the AO CPE should be able to support an 8 x 4 Docsis downstream/upstream carrier system with a tuner receive window of at least 200Mhz. Full spectrum capture tuners are recommended for future flexibility.

5.1.2 Euro-Docsis 3.0 physical layer TLN specific requirements

- (15) TLN requires the use of 256QAM modulation on Docsis downstream carriers, as such the support of 256QAM is a mandatory requirement. TLN requires the use of 16QAM and 64QAM A-TDMA modulation on Docsis upstream carriers, with fallback to 8QAM and QPSK as such support of those modulations and the fall back mechanisms are mandatory requirements.
- (16) TLN also requires the support of S-CDMA, with an as broad as possible range of supported modulation schemes developed for data transmission across coaxial cable networks. S-CDMA allows multiple subscribers connected to the network to transmit concurrently. This method of data transmission was developed to be extremely resistant to impulse noise.
- (17) TLN requires the support of TLV1 en TLV41 redirection mechanisms.

5.2 Older Docsis versions

- (18) The TLN network is closed for deployment of Docsis 2.0, Docsis 1.x or any other non Docsis 3.0 compliant CPE equipment

5.3 TLN Docsis spectrum plan

5.3.1 Docsis downstream carriers frequency plan

- (19) The AO CM must be conform to the Docsis 3.0 physical layer specifications to be interoperable with the Telenet downstream spectrum plan.

5.3.2 Docsis downstream RF signal coding and signal levels

- (20) TLN requires AO Docsis CPE to communicate with TLN CMTS on the downstream path of TLN HFC network on a 8-MHz wide as a Euro-Docsis standard, 256-QAM digitally encoded RF signal with detailed RF signal requirements as specifiend in appendix 1.

5.3.3 Docsis upstream carrier low and high band plan

- (21) The Telenet network uses two RF spectrum ranges (in some parts of the TLN network) in the upstream part of the HFC spectrum for transmission of upstream Docsis carriers. Those are called the “low” upstream band and the “high” upstream band.
- (22) The “low” upstream band ranges from 5-25 Mhz and the “high” upstream band from 25-65 Mhz.

- (23) An AO modem may have to attach either to the Docsis carriers in the “low” band or in the “high” band depending on the local situation of the cable plant which differs from region to region. RF signal conditions and used modulation schemes may differ in the different bands.
- (24) The possibility for a modem to connect to a given band also depends on “local” conditions such as for example the presence of NIU types with a 5-25 MHz low pass upstream filter or eventually outside plant network elements that might block access to the “high” band. This will imply that not all advertised upstream channels will be available to the AO CPE in a uniform way over the entire Telenet Network.
- (25) Telenet is actively using network management techniques to allocate and switch modems from time to time between upstream channels to keep the upstream spectrum as clean as possible from RF ingress noise and to balance traffic. The AO modems should be fully capable of supporting and responding to all those Docsis management instructions received from the Telenet CMTS. Please refer to the Euro-Docsis MULPI specification for more details. The AO modem must be conform with the Euro-Docsis MULPI specifications (especially section 6.4.10, 6.4.22, 6.4.20, 6.4.21, 6.4.22, 6.4.29, 6.4.30, 6.4.31 and section 11.3, 11.4 and 11.5)

5.3.4 Docsis upstream carriers frequency plan

- (26) According to Euro-Docsis standards, the upstream (US) part of the spectrum range is in between 5 MHz and 85 MHz. The TLN network is currently only using the spectrum range between 5 Mhz and 65Mhz, but this could change in the future.

5.3.5 Docsis upstream RF signal coding and signal levels

- (27) AO Docsis CPE will communicate with TLN CMTS on the upstream path of TLN HFC network on one or multiple (bonded) 3,2 and/or 6.4 MHz wide upstream channel(s), using a phase shift keying modulation (QPSK), a quadruple amplitude modulation (8-QAM, 16-QAM, 32-QAM or 64-QAM), a A-TDMA or S-CDMA (both with a wide range of modulation schemes) digitally encoded RF signal.
- (28) The AO Docsis CPE will have to support the above mentioned modulation schemes to successfully interoperate with the TLN network. The AO Docsis CPE must be conform with all specifications in the Euro-Docsis PHY in section 6.

5.3.6 Docsis upstream hopping channel concept

- (29) The frequencies used for the upstream traffic are under the control of the TLN CMTS and are pre-defined. Therefore, the ability for a modem to “avoid” the use of particular frequencies is under the control of TLN.
- (30) Additionally, channels in the return path that are subject to ingress or to impulse noise can be (temporary) automatically or manually “shut down” for use or the modulation can be switches to a lower, more robust one. This technique is referred as “modulation hopping”. Modulation hopping concept is used in upstream Channel sequence on TLN Network and should be fully supported by AO modems.
- (31) Telenet uses advanced spectrum management techniques in order to adapt the network as good as possible towards dynamically changing spectrum quality in upstream. This is done by signaling via UCD changes on the characteristics of the US channels.
- (32) In addition Telenet also uses a load balancing technique (using DCC, DBC) on US channels to keep the total upstream traffic as balanced as possible, by “instructing” certain modems from time to time to change US channel.

5.4 TLN Docsis ranging and carrier signalling procedures

(33)For all details regarding Docsis ranging, please refer to section 10.2 of the Euro-Docsis MULPI specification.

5.5 TLN Docsis carrier spectrum plan

(34)The modem should comply with the EuroDocsis standards and so the modem will tune automatically to the needed spectrum. The modem will typically scan the network to find out the frequencies to be used.

6 AO Euro-Docsis 3.0 CPE MAC and Upper Layer Functional Description

- (35)The AO Docsis CPE is the equipment, required to connect an AO customer to the TLN HFC network with as purpose to provide broadband internet connectivity in the customer household. There are typically two main building blocks present in a Docsis CPE device: the “physical interface layer” used to establish the RF connectivity and Docsis physical layer communication between the Docsis CPE and HFC Network, and the “data interface communication layer” used to establish the “data communication path” with the help of MAC and IP layer interfaces’ addresses and control plane protocols. Since the TLN network operates in compliance to the Euro-Docsis standards variant of the Docsis standards framework, all the requirements and references should be read as being referred to the Euro-Docsis perspectives of the standards.
- (36)There are a number of important specifications that AO Docsis CPE should support for MAC, IP and upper layer communication. These specifications describe how the AO Docsis CPE should react to provide connectivity with TLN HFC Network, what security conditions AO Docsis CPE should reselect, and which features should be present in the AO Docsis CPE to interoperate with TLN CMTS within the Docsis Operation Support System Interface specifications domain.

7 AO Euro-Docsis 3.0 CPE MAC and Upper Layer Functional Requirements

7.1 Euro-Docsis 3.0 MAC and upper Layer

7.1.1 Euro-Docsis 3.0 Mac and upper layer general requirements

(37) In order to ensure successful interoperability on the MAC layer, IP layer and the upper layers the AO Euro-Docsis CPE device must be in conformance with the Docsis 3.0 MAC and upper layer specifications (Euro-Docsis variant) as published in the public Docsis 3.0 specification library on www.cablelabs.com.

7.1.2 Euro-Docsis 3.0 Mac and upper layer TLN specific requirements

(38) The TLN network implementation is fully in accordance with the Euro-Docsis specifications. As such no specific TLN requirements are applicable. However the Euro-Docsis specifications allow an operator to choose a number of implementation options within the framework of the specifications. Those implementation options are mainly related to the domains of device provisioning, address management, device configuration and security. The implementation options that TLN has chosen in those domains are explained further in this document.

7.2 Euro-Docsis 3.0 Security

7.2.1 Euro-Docsis 3.0 Security layer general requirements

(39) As Docsis modems are operating on a shared access medium a strict compliance to the Docsis security specifications (Euro-Docsis variant) on the MAC layer and upper layers for the AO Euro-Docsis CPE as published in the public Docsis 3.0 specification library on www.cablelabs.com.

7.2.2 Euro-Docsis 3.0 Security layer TLN specific requirements

(40) The TLN network implementation is fully in accordance with the Euro-Docsis specifications. As such no specific TLN requirements are applicable. However the Euro-Docsis specifications allow an operator to choose a number of implementation options within the framework of the specifications. Those implementation options are mainly related to the domains of device provisioning, address management, device configuration and security. The implementation options that TLN has chosen in those domains are explained further in this document.

7.3 Euro-Docsis 3.0 OSSI

7.3.1 Euro-Docsis 3.0 OSSI general requirements

(41) In order to guarantee seamless interoperability with the TLN CMTS systems in the domains of network management and provisioning a strict compliance is required for the AO Euro-Docsis CPE to the Docsis Operations Support Systems Interface (OSSI) specifications (Euro-Docsis variant) as published in the public Docsis 3.0 specification library on www.cablelabs.com.

7.3.2 Euro-Docsis 3.0 OSSI TLN specific requirements

(42) The TLN network implementation is fully in accordance with the Euro-Docsis specifications. As such no specific TLN requirements are applicable. However the Euro-Docsis specifications allow an operator to choose a number of implementation options within the framework of the specifications. Those implementation options are mainly related to the domains of device provisioning, address management, device configuration and security. The implementation options that TLN has chosen in those domains are explained further in this document.

7.4 Euro-Docsis 3.0 BSOD: L2VPN

7.4.1 Euro-Docsis 3.0 BSOD: L2VPN general requirements

(43) In order to guarantee seamless interoperability with the TLN CMTS systems in the domains of network management and provisioning a strict compliance is required for the AO Euro-Docsis CPE to the Docsis BSOD Layer2 Virtual Private Network (L2VPN) specifications (Euro-Docsis variant) as published in the public Docsis 3.0 specification library on www.cablelabs.com.

7.5 Older Docsis versions

(44) The TLN network is closed for deployment of Docsis 2.0, Docsis 1.0 or any other non Docsis 3.0 compliant CPE equipment. The only Docsis version on AO Docsis CPE must be Docsis 3.0.

7.6 AO CPE MAC and IP layer provisioning: “Off-line” stage

7.6.1 AO Docsis CPE asset white list upload

(45) TLN requires a list (white list) of HFC MAC addresses (and some related information) of AO customer CPEs per AO, at least two weeks prior to the potential installation and connection to the TLN HFC network of a device on this list by the AO. This implies that an upload mechanism and related process is foreseen to allow transfer of those lists on a regular basis. These HFC MAC addresses are configured in the TLN NCP inventory databases with the default profile for each AO operator. Based on these HFC MAC addresses, TLN authenticates devices before granting them access to the cable network.

(46) If the AO does not upload HFC MAC addresses upfront, the onsite technician or eventual self install procedures for the AO will fail. In that case, the AO CPE modem will be treated as a not provisioned Telenet modem and redirect to the Telenet self install portal when it tries to come online. No further interaction will be possible in this case, until the AO has uploaded the HFC MAC address for this modem as described above. The upload time slot windows and the time periods between the upload of the modem list and the first moment in time such a modem can become active in the network is described in the technical processes documents.

7.6.2 AO Docsis CPE modem configuration template upload

(47)The AO must upload AO CPE modem configuration files for each cable modem type that has earlier been uploaded on the white list (as described above) on a TLN NCP configuration server. A modem configuration file will be linked to an individual HFC MAC address by including this individual MAC address as part of the configuration file name. The configuration file contains the required parameters that the modem needs to get connectivity and establish data path between the TLN and AO networks. TLN requires configuration files to be uploaded upfront to avoid excessive real time interactions between AO and TLN NCP systems when the modem comes online.

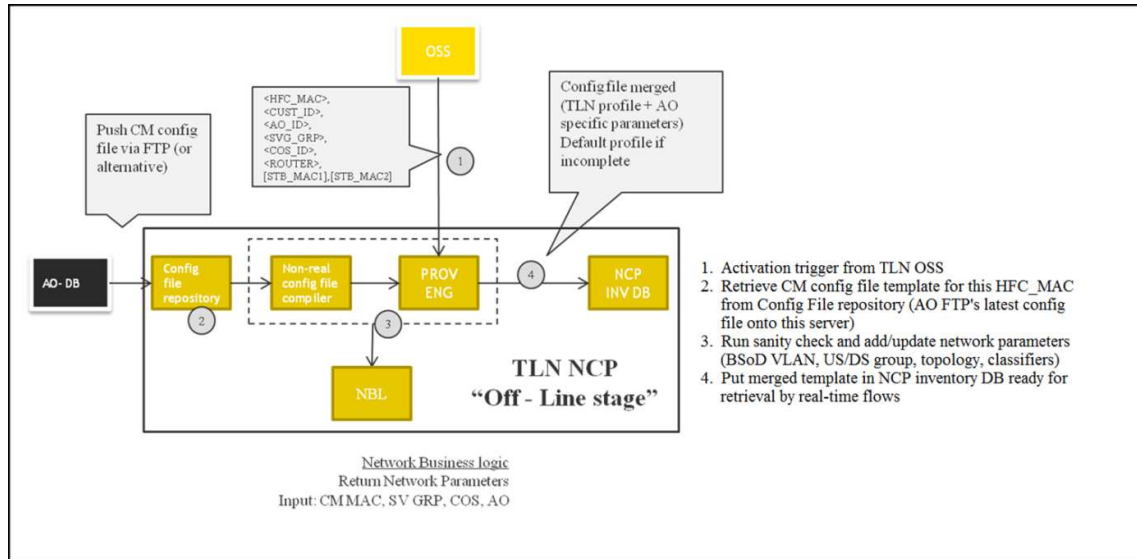

Figure 7-1: AO Docsis CPE modem configuration

7.7 AO CPE MAC and IP Layer provisioning: “On-line” stage

7.7.1 AO Modem activation flow

(48) In the description of the “Off-line” stage process above (figure 4-1) it has been explained how an AO can upload lists of Docsis CPE devices and their related configuration files into the NCP inventory database (LDAP). Further it has been shown how TLN runs sanity checks on the AO provided configuration files and how it adds /updates network parameters (BSoD vlan, US/DS groups, topology information, classifiers, shared key etc.) describing how the TLN network will transport the traffic of AO customers to the hand-over points and how it stores the merged final AO modem configuration files in the NCP LDAP inventory database.

(49) After this “off-line” stage the network is fully prepared for the first time activity of the AO modem to complete the process. This next step will be triggered as explained further by the AO modem trying to acquire an IP address.

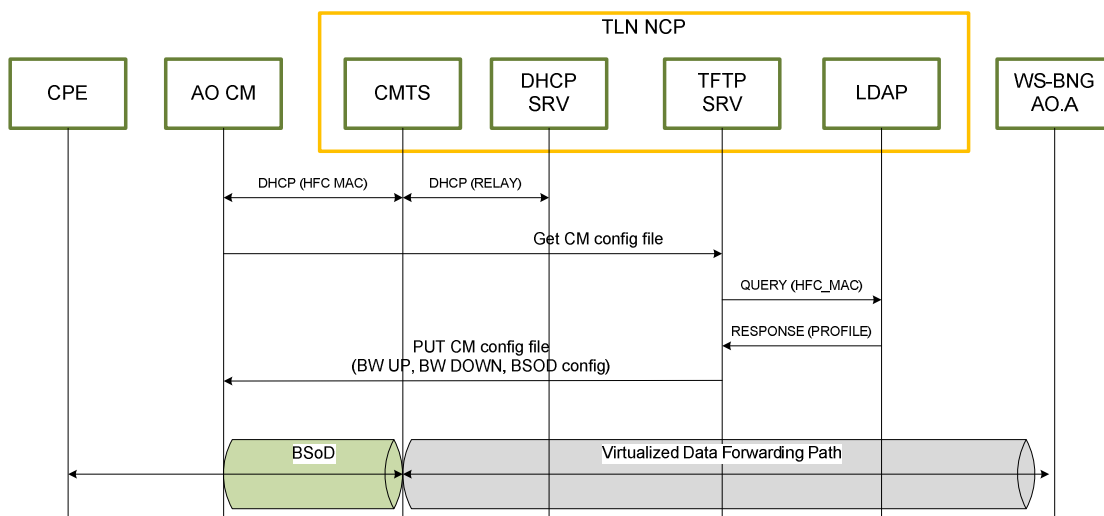

Figure 7-2 : AO Modem Activation Flow

7.7.2 AO Docsis CPE “Management” IP address Assignment

(50) The “on-line” modem initialization process is triggered by the AO Docsis CPE (CM) launching a DHCP discovery which contains parameters like vendor-type, modem type, DOCSIS capabilities and HFC-MAC-ID. The TLN-NCP checks the AO-ID by using HFC-MAC-ID if it is white listed in TLN NCP inventory database and if the request originates from the correct geographical area and if all parameters are corresponding to the prior provisioned configuration info.

(51) If all above checks are positive, the TLN-NCP will send a DHCP offer message to the CM containing management IP address, IP addresses of TFTP and TOD servers and name of initial modem configuration file. If the checks are negative, an error event will be logged and the modem will not be able to get in “on-line” status.

7.7.3 AO Modem configuration

(52) After the modem has acquired its management IP address, it will ask for its configuration (identified via the HFC-MAC-ID) file to TLN-TFTP server (NCP). Then the modem gets date/time with TOD server.

(53) The modem configuration file contains, among other parameters, BSoD vlan. With the help of this info the path towards the WS-BNG is established and the modem is ready to start interacting with the AO network and systems.

7.8 IP Layer Connectivity for AO Docsis CPE

7.8.1 BSoD

(54) After AO CPE "management" IP address acquisition and completion of the modem configuration process all the data traffic originated from the "LAN" side of the modem will be switched by the modem and delivered at the correct endpoint on the CMTS using BSoD. The traffic will then be VLAN encapsulated by the CMTS and forwarded to the WS-BNG. (Eventual STB return path traffic follows same flow).

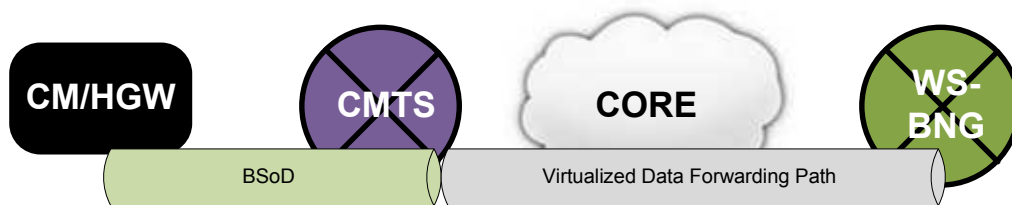

Figure 7-3 : BSoD

(55) BSoD provides a transit path over the TLN HFC network from the AO CPE to the CMTS, from where there is a virtualized forwarding path to the WS-BNG. The use of the BSoD mechanism provides a clean architecture where on the IP layer and on IP address space level the AO Backbone network to AO Household connectivity and routing and address management aspects are clearly separated from the TLN network in a transparent way.

7.8.2 Access Authentication

(56) The AO CPE sends a DHCP discovery message to the AO DHCP Server in order to get its Public IP address, after finalizing the initial BSoD data path establishment. Then HGW/CM forwards the request over the appropriate BSoD path based upon the info that resides in the CM configuration file.

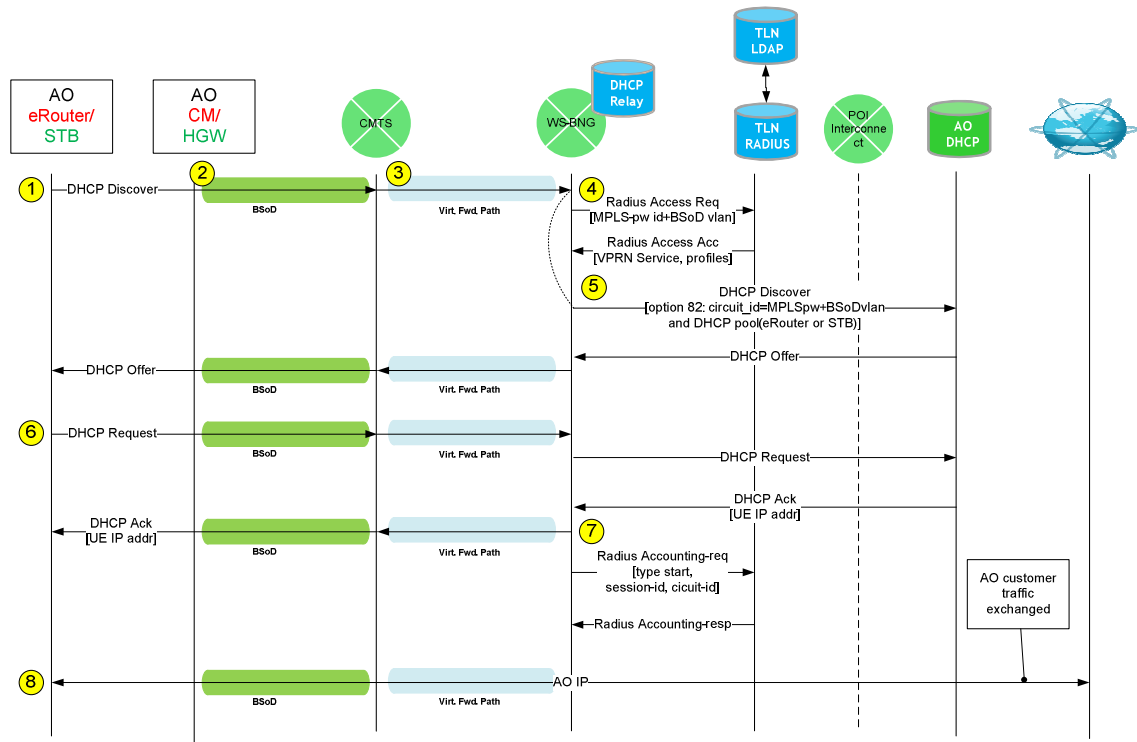

Figure 7-4 : Access Authentication

(57)When the discover message reaches the WS-BNG, it will temporary keep the message and sends a Radius access request message to the Telenet NCP Server :

- If access is granted, the WS-BNG relays the DHCP discovery to the AO NCP Server (DHCP) and correspondingly an IP address will be assigned by the AO NCP.
- If access is denied; as a reason of e.g. TLN inspection of malicious subscriber i.e.; DHCP discovery is dropped and a logging event is generated.

(58)Then the WS-BNG snoops the AO NCP DHCP ACK message in order to follow subscriber state and forward traffic to the correct CPE.

7.8.3 IP Address assignment

(59)The DHCP Discovery Message is replied to by the AO DHCP Server, since the AO is responsible for IP address assignment to the AO CPE via DHCP. The AO will have to provide IP address ranges per RPOI of sufficient size in order to avoid excessive change requests. The AO is also responsible for its own policy management to deploy in its AO Backbone Network.

(60)An AO STB should set DHCP option 60 as a Vendor Class Identifier to identify the STB easily. If the TLN NCP detects malicious attempts from AO CPE, TLN has the right to reject the DHCP discovery messages and drop them.

(61)TLN has the right to differentiate the given IP pool as Docsis CPE Pool, STB Pool etc. and ask the AO to provide appropriate public IP address ranges for each.

8 AO Device Management by TLN Requirements

8.1 Concept and purpose

- (62) In order to provide effective support to AO during problem diagnosis, TLN requires a minimum non-intrusive management access to AO CPE devices connected to its HFC network. This will be realized by implementing a “minimum” SNMP MIB and related set of actions on it that can be executed by TLN as described in this section.
- (63) For sake of clarity: device management as described here relates to management of the “modem” or “Docsis” component of the AO CPE device that provides the connectivity and transport service on the Docsis layer towards the TLN CMTS over the TLN HFC network.
- (64) Overall management access by AO to its devices is provided by TLN. The possibilities and restrictions of this are described in the document: [TLN_WRO_TA_G_S_PAAB - Specification Device Management](#).

8.2 Device management Functions

Device management executed by TLN

- (65) Telenet requires following minimum device management capabilities to be available on AO CPE for execution by Telenet (Execution of Telenet of below described management actions will only occur in cases where a particular AO CPE device behaves in a way that Telenet network integrity or security is compromised, a practical example could be, a given modem that launches DOS attacks by generating excessive packet burst, or is identified as being the source of excessive noise injection) :
- a. Remote modem reset via SNMP
 - b. Remote modem disabling (modem deny) via SNMP
 - c. Remote US en DS FTP upload/download test.
 - d. Remote SNMP query on DOCSIS related MIB as specified in the section 4.3.3 below.

Device management available to AO

- (66) Telenet offers via above described management function a tool set and environment allowing AO's to implement its own customer OAM and care system. This will allow AO's to build on-line view of their customers and allows some functionalities like view status of AO customer, do a link speed test, suspend/not suspend network access for AO CPE, do connectivity loopback tests, and providing of read/write SNMP access for certain CPE parameters etc.

8.3 SNMP MIB specifications

- (67) Management Information Bases (MIBs) are a collection of objects or definitions that define the properties of managed objects. TLN needs to know the names and types of a subset of objects on AO Docsis CPE (CM) to enable the TLN SNMP manager or management application to perform a minimum subset of operations on AO CPE equipment that are required for successful operation of the network.
- (68) Minimum DOCSIS MIB implementations on AO DOCSIS CPE for access by TLN should be as follows :
- iso.org.dod.internet.mgmt.mib-2.docsisDev (1.3.6.1.2.1.69)
 - [\[RFC 2669\]](#) DOCSIS Cable Device MIB Cable Device Management Information Base for DOCSIS compliant Cable Modems and Cable Modem Termination Systems

- [\[RFC 2670\]](#) Radio Frequency (RF) Interface Management Information Base for MCNS/DOCSIS compliant RF interfaces.
- [\[RFC 3083\]](#) Baseline Privacy Interface Management Information Base for DOCSIS Compliant Cable Modems and Cable Modem Termination Systems.
- Telenet private MIB for US/DS FTP test

(69) The formal definition of this subset of objects, parameters and the operations on them are provided in the format of an SNMP MIB definition in [TLN_WRO_TA_G_S_PAAB - Specification Device Management](#).

8.4 Reset and Factory Reset specifications

(70) The AO Docsis CPE (CM) must have basic reset functions. It is important to have these functions to provide assistance on troubleshooting. The AO device may have a reset button on it, and should provide a factory reset option as well. Reset options may provide a reboot and connection loss for 5 to 30 minutes.

9 AO Euro-Docsis 3.0 CPE-Non Functional Requirements

9.1 Mechanical Requirements

9.1.1 Housing

(71)TLN does not impose any requirements as this is the responsibility domain of the AO. However it is strongly advised to AO to follow industry standard practices.

9.1.2 Diagnostic Leds

(72)An AO CM should have a minimum of five externally visible LEDs divided into three functional groups.

(73)BOX: This group should have 1 LED labeled as POWER for the BOX status.

(74)DOCSIS: This group should have 3 LEDs labeled as DS, US, and ONLINE for the DOCSIS interface status. The LEDs in the DOCSIS group should be in the order: DS, US, and ONLINE, from left to right, or top to bottom, as appropriate for the orientation of the device.

(75)CPE: This group should have a minimum of 1 LED labeled as LINK for the LINK status. The AO CM may have multiple LEDs in the CPE group to represent individual CPE interface types and parameters. These CM CPE LEDs may be labeled according to their associated interface types.

(76)An AO CM should support LEDs which have three states: 1) unlit, 2) flash, 3) lit solid and 2 colors for DS, US: 1) green (non-bonded channels), 2) blue (bonded channels)

9.1.3 Labels

(77)TLN does not impose any requirements as this is the responsibility domain of the AO. However it is strongly advised to AO to follow industry standard practices.

(78)In addition the logo of the AO must be clearly visible on the device to facilitate customer support and repair actions, giving as such a clear visual indication if a CPE in a customer's home is owned by TLN or one of the AOs' .

9.1.4 Connectors

(79)Coax connectors, must be F type connectors (IEC169-24). Specifications, for this type of connector, are as bellows;

(80) Torque resistance: 4Nm

Inner conductor:

Minimum diameter 0,57mm, clamping force 30 grams

Nominal diameter 0,8mm, clamping force 50 grams

Maximum diameter 1,0mm, clamping force 80 grams

(81) The only connector which has specific requirements imposed by TLN is the coax connector towards the NIU, the rest is AO choice, however TLN recommends following as much as possible industry standards.

9.2 Environmental Requirements

9.2.1 Packaging

(82) TLN does not impose any requirements as this is the responsibility domain of the AO. However it is strongly advised to AO to follow industry standard practices.

9.2.2 RoHS and WEEE compliancy

(83) RoHS is defined as the directive on the restriction of the use of certain hazardous substances in electrical and electronic equipment on 2002/95/EC and the abbreviation for Restriction of Hazardous Substances. This directive is closely linked with Waste Electrical and Electronic Equipment Directive (WEEE) - 2002/96/EC.

(84) These directives are in the responsibility domain of AO, and TLN does not impose any requirements. AO is strongly advised to follow the standards and the requirements imposed by law about RoHS.

9.2.3 EU CoC compliancy

(85) TLN does not impose any requirements as this is the responsibility domain of the AO. However it is strongly advised to AO to follow industry standard practices and any requirements in this domain imposed by law should be met.

9.3 Safety Requirements

9.3.1 Surge and Lightning protection

(86) TLN requires that AO CPE devices are protected against over-voltages on their different interfaces. This is to guarantee customer safety under all conditions and to protect other CPE equipment.

(87) The exact requirements are listed in [Appendix 1:Telenet.CNG.AINE-QCR-CM-EMTA-Lightning-REQ-20080730](#) to this document

9.3.2 Temperature and Humidity

(88) TLN does not impose any requirements as this is the responsibility domain of the AO. However it is strongly advised to AO to follow industry standard practices.

9.3.3 Fire resistance

(89) TLN requires AO to select equipment that has at least protection class 121, and has all parts halogen free / self-extinguishing. In the below figure, some of the important safety requirements standards are listed.

(90) It should be noted however that being fully compliant with all legal requirements for CPE is the full and sole responsibility of the AO.

EN 41003	1998	Particular safety requirements for equipment to be connected to telecommunications networks
EN 50083-1 /A2	1997	Cabled distribution systems for television, sound and interactive multimedia signals; Part 1: Safety requirements
EN 60950	2000	Safety of information technology equipment, including electrical business equipment

Figure 9-1: Safety Requirements Standards

9.4 EU Consumer Goods label Requirements

9.4.1 CE - mark

(91)CE marking (originally EC mark) is a mandatory conformity mark for products placed on the market in the European Economic Area (EEA). With the CE marking on a product the manufacturer ensures that the product conforms to the essential requirements of the applicable EC directives. The letters "CE" stand for "Conformité Européenne" ("European Conformity").

(92)This conformity is in the responsibility domain of AO, and TLN does not impose any requirements. AO is strongly advised to follow the standards and the requirements imposed by law.

10 Certification procedures for AO Euro Docsis 3.0 CPE to enable usage of TLN ROBB

10.1 Introduction

(93)The tests will cover all of the requirements specified by TLN in this specification.

11 Test score card

CONFORMANCE TEST SCORE CARD					
Conformance Test Score Card Number	TLN-WRO-TA-TSC-%-P% %%				
Test Identification					
Test Execution Date					
Test Run Type	Full / Reduced(without OOS cases)				
Device / Equipment / Interface Name					
Device / Equipment / Interface Type / Class					
AO Device / Equipment / Interface Identification					
Software Version					
Tested by					
Overall Result Status	Pass / Fail				
Applicability	Select 1 or more : ROTV / ROBB / AIDTV				
CONFORMANCE TEST ITEM LIST					
Test Cases Summary	FORMAT	IN SCOPE	MAN	PASS/FAIL	REM
			"Y/N"	"P/F"	(*xy)
3. AO Euro-Docsis 3.0 CPE General Functional Requirements	HO				
3.1. AO Euro-Docsis 3.0 CPE Hardware and OS			Y		
3.2. Euro- Docsis MAC and IP layer			Y		
5. AO Euro-Docsis 3.0 CPE HFC and Euro-Docsis 3.0 Physical Layer Functional Requirements	HO				
5.1 EURO-DOCSIS 3.0 PHYSICAL LAYER			Y		
5.2 OLDER DOCSIS VERSIONS			Y		
5.3 TLN DOCSIS SPECTRUM PLAN			Y		
5.4 TLN DOCSIS RANGING AND CARRIER SIGNALLING PROCEDURES			Y		
5.5 TLN DOCSIS CARRIER SPECTRUM PLAN			Y		
7 AO Euro-Docsis 3.0 CPE MAC and Upper Layer Functional Requirements	HO				
7.1 EURO-DOCSIS 3.0 MAC AND UPPER LAYER			Y		
7.2 EURO-DOCSIS 3.0 SECURITY			Y		
7.3 EURO-DOCSIS 3.0 OSSI			Y		
7.4 EURO-DOCSIS BSOD L2VPN			Y		
7.5 OLDER DOCSIS VERSIONS			Y		
7.6 AO CPE MAC AND IP LAYER PROVISIONING: "OFF-LINE" STAGE			Y		

7.7	AO CPE MAC AND IP LAYER PROVISIONING: "ON-LINE" STAGE			Y		
7.8	IP LAYER CONNECTIVITY FOR AO DOCSIS CPE			Y		
8	AO Device Management by TLN Requirements	HO				
8.1	CONCEPT AND PURPOSE			Y		
8.2	DEVICE MANAGEMENT FUNCTIONS			Y		
8.3	SNMP MIB SPECIFICATIONS			Y		
8.4	RESET AND FACTORY RESET SPECIFICATIONS			Y		
9	AO Euro-Docsis 3.0 CPE–Non Functional Requirements	HO				
9.1	MECHANICAL REQUIREMENTS			Y		
9.2	ENVIRONMENTAL REQUIREMENTS			Y		
9.3	SAFETY REQUIREMENTS			Y		
9.4	EU CONSUMER GOODS LABEL REQUIREMENTS			Y		
Remarks						
(*xy) : "Remark explanation comes here"						