

# TLN WRO Specification type Document

< Specification NIU Interface >



**telenet**

## Document Housekeeping

### Document Category and type

CAT	TYPE	DOC ID	Comment
General	SPEC	TLN_WRO_TA_G_S_PAAA	<b>Specification type documents (-SPEC) are documents specifying logical / physical interfaces / protocols, etc..., to which AO equipment/systems need to comply</b>

### Document Status

EDITION	DATE	STATUS
1.0	09.10.2013	Final
1.1	23.07.2014	Final
2.0	29.12.2018	Final

### Legal Disclaimer

"This document constitutes an integral part of the Telenet Reference Offer for Basic TV / IDTV / BB and should be fully complied with by the Beneficiary at all times. Non compliance, incomplete or deviating application of this document by the Beneficiary, or his authorized agent, results in the suspension and ultimately termination of the Contract between Telenet and the Beneficiary.

At any time this document is susceptible to change by Telenet, Regulator's decision or by decision of a relevant judicial authority. Changes to this document will, depending on the circumstances for change, be appropriately notified to the Beneficiary and published on the Telenet website.

Telenet has appealed the CRC decisions of the VRM, BIPT and CSA of 29 June 2018 concerning the market analysis of the broadband and broadcasting market in Belgium and it consequently reserves all its rights in relation to this document."

## Table of Contents

1	Abstract .....	5
2	NIU Interface Ports Functional Description .....	6
3	NIU Interface Ports Functional Requirements .....	7
3.1	NIU PHYSICAL APPEARANCE VIEW .....	7
3.1.1	<i>General</i> .....	7
3.1.2	<i>Distribution ports</i> .....	8
3.1.3	<i>Cable modem ports</i> .....	9
3.1.4	<i>Other ports</i> .....	9
3.1.5	<i>Life line support</i> .....	9
3.2	NIU RF FUNCTIONALITY .....	10

## Table of Figures

Figure 2-1:	NIU Interface Ports.....	6
Figure 3-1:	NIU Physical View .....	7
Figure 3-2:	Wall Outlet .....	8
Figure 3-3:	NIU RF Example.....	10

## List of Appendixes

This document may refer to further detailed documents that are added in Appendixes to this document.

A reference to an appendix is in this document highlighted with grey background.

The list with appendixes of this document:

None.

## List of References

This document may refer to external documents or information sources.

A reference to an external document or information source is in this document highlighted with grey background.

The list of referred external documents or information sources in this document:

Reference 1: TLN\_WRO\_TA\_G\_S\_PAAC - Toepassing van Installatie

## Restricted information

This document may contain sections that are not public information and that can be made available only to parties that have executed specific NDA`s.

Information that is subject to NDA is marked in this document as follows:

NDA  
NDA

The information in this text box is available only under NDA

Before conversion to PDF format for publication of the document, the information will be made unreadable by converting the background of the text box to black.

## 1 Abstract

This document describes the interface ports on the Telenet Network Interface Unit (NIU) that are available for connecting AO CPE equipment to the Telenet network. The NIU is the main interface and demarcation point with the Telenet network.



### 3 NIU Interface Ports Functional Requirements

#### 3.1 NIU Physical appearance view

##### 3.1.1 General

- (4) The below figure reflects a typical block diagram of a NIU that will be installed by a certified technician of the AO (unless a suitable NIU is already present) in a customer home that will be prepared for wholesale as a consequence of an AO acquiring this customer as its own customer. The NIU type to be installed may change over time.

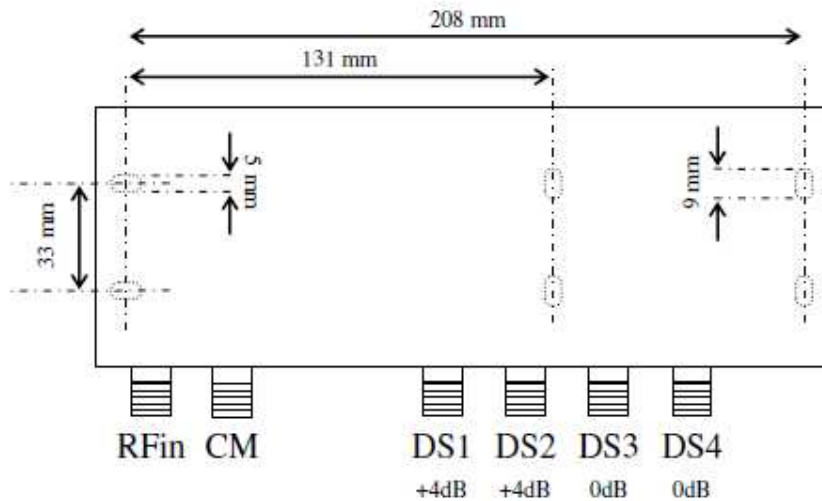

Figure 3-1: NIU Physical View

- (5) A comprehensive variety of different NIU types are currently deployed in the field that differ in form factor, appearance and capabilities.
- (6) An important difference between NIU types will be the number of available ports to connect AO equipment. The block diagram above (figure 4-1) shows the schematic lay-out of an NIU with single cable modem port and four downstream ports. The figure below (figure 4-2) shows the block diagram of a compact “Wall-outlet” type NIU with one cable modem port and one downstream port. Several other variants not listed here are present in the network.

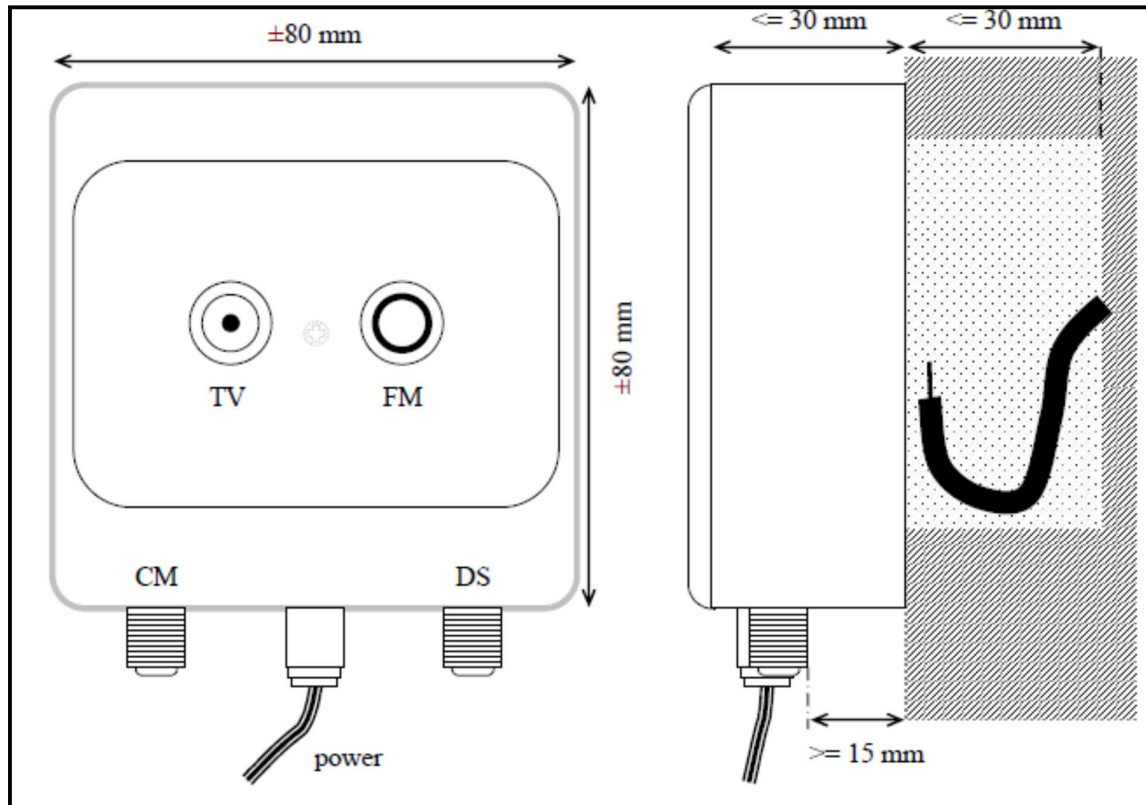

Figure 3-2: Wall Outlet

- (7) The decision rules that determine whether or not a NIU need to be installed, or an existing NIU need to be replaced by another type and the process to make this decision for a given customer as well as the installation policies and usage rules of the different ports on NIU's are described in general annex: [TLN\\_WRO\\_TA\\_G\\_S\\_PAAC - Toepassing van Installatie](#).

### 3.1.2 Distribution ports

- (8) The Distribution ports are typically (other labels may also occur) marked DS or DSx. They are unidirectional ports passing on the RF signals coming from the TLN network towards the home (Downstream), but will filter (attenuate) any signal that would be offered on such a port in the direction from the home towards the network (Upstream).
- (9) The purpose of those distribution ports is to connect Wall Outlets for distribution of analog TV and FM radio in the home or to connect Wall Outlets with as purpose to connect the DVB-C tuner (RF-in on STB) port of an AO Digital STB via an RF patch cord.
- (10) For sharing rules: see general annex [TLN\\_WRO\\_TA\\_G\\_S\\_PAAC - Toepassing van Installatie](#).
- (11) Mechanical requirements for connectors :

- NIU RF connectors are F (IEC169-24), torque resistance: 4Nm
- Inner conductor:
  - Minimum diameter 0,57mm, clamping force 30 grams
  - Nominal diameter 0,8mm, clamping force 50 grams
  - Maximum diameter 1,0mm, clamping force 80 grams



- Connections between AO CPE and NIU need to be realized with TLN approved RF patch cords or jumper cables. Specifications of those are included in the “TV” category of the technical annexes to the TLN WRO.

### **3.1.3 Cable modem ports**

- (12)The Internet ports are marked CM, or CM1 and CM2. In addition other labeling of those ports may also occur. They are bi-directional ports passing on the RF signals coming from the TLN network towards the home (Downstream), and will send the signals that are offered on such a port in the direction from the home towards the network (Upstream).
- (13)The purpose of those Internet ports is to connect cable modems that enable two way data communication from the home towards the Internet.
- (14)For sharing rules: see general annex **TLN\_WRO\_TA\_G\_S\_PAAC - Toepassing van Installatie**.
- (15)As HFC networks are vulnerable towards RF ingress noise, especially in the upstream direction, very strict installation policies will be applied on the application of “good workmanship” during the connection and cabling towards those ports.

### **3.1.4 Other ports**

- (16)The other ports are not available for wholesale use and any attempt to connect equipment to those ports will result in a repair intervention of a Telenet technician which will be charged towards the AO.

### **3.1.5 Life line support**

- (17)Certain NIU types are equipped with life line support, meaning that when the AC power sources that feeds the NIU fails, it will still provide a minimal RF signal transfer function at lower RF power levels, based on a galvanic bridge function automatically coming into force by absence of AC power.
- (18)It's the AO's choice to determine if it will design its CPE equipment in such a way that it can still provide basic services or not in these conditions.

### 3.2 NIU RF functionality

(19) The function of the NIU in the RF domain is shown in the figure below. The below diagram is an example and describes the most complex NIU type that is present in the field, having lifeline support, 2 CM ports and 4 DS ports. The principles of operations of other type of NIU's are similar but certain ports or functions may be absent.

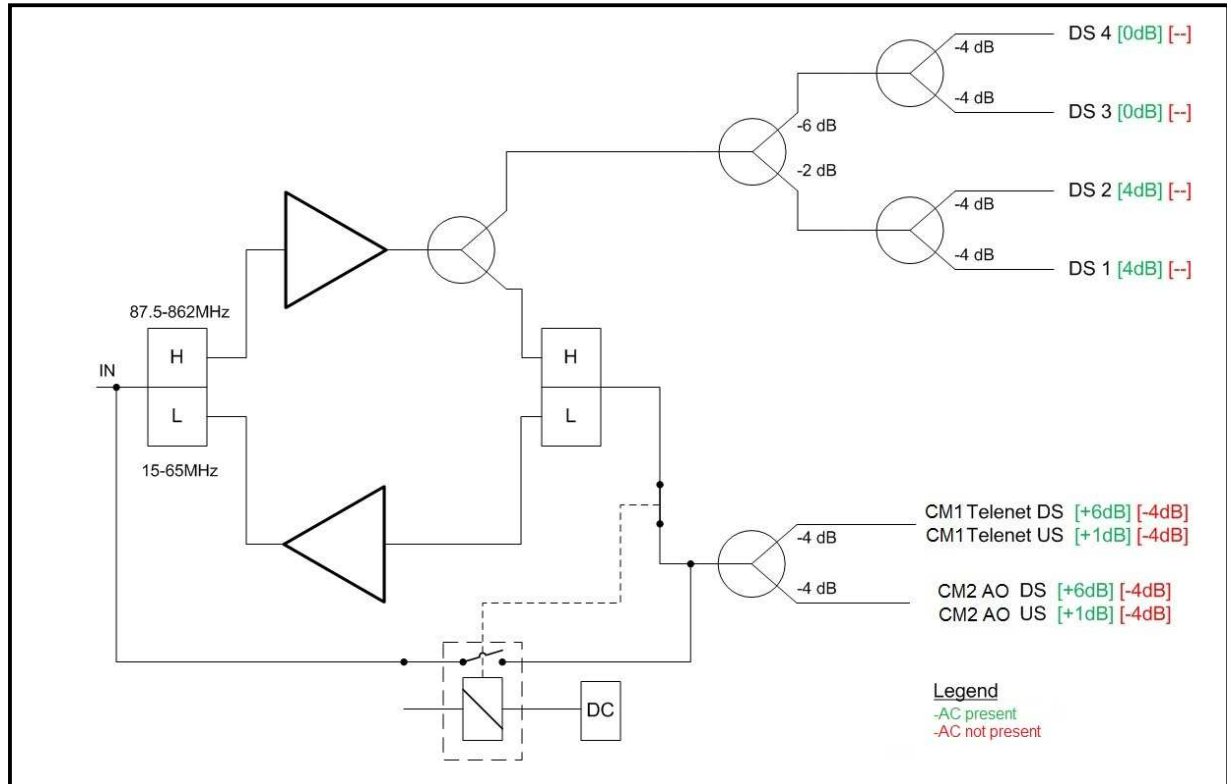

Figure 3-3: NIU RF Example

(20) It should be noted that requirements on RF signals for AO CPE equipment (modem and STB) are not imposed by the NIU as such, but rather by the TLN equipment deeper in the network that “terminates” or “generates” the RF signals from and to the AO CPE after transport over the HFC network. As such the requirements on RF level for an AO modem or STB are not provided here, but in the respective documents describing the requirements for those devices.

(21) From above figure it can be seen (green figures) that for the Distribution Ports, two ports (DS4 and DS3) are signal level neutral (signal has same strength as at NIU entrance) and two ports (DS1 and DS2) offer a 4dB gain due to the built in amplifier. As stated before several other NIU types exists having more limited capabilities.

(22) From above figure it can be seen (green figures) that for the Internet ports (CM1 and CM2) the NIU offers a 6dB gain in DS and a 1dB gain in US due to the built in amplifier.

(23) The figures in red give the signal levels when the AC power source is not present. Please note that the 4 Distribution ports are disabled in this case and that the 2 internet ports will experience 4 dB attenuation.